

Government of Karnataka
Department of Technical Education
Board of Technical Examinations, Bangalore

	Course Title: BUILDING PLANNING AND DRAWING		
	Credits (L:T:P) 0:2:4	Total Contact Hours: 78	Course Code: 15CE35D
	Type of Course: Practical, Case study	Credit :03	Core/ Elective: Core
CIE- 25 Marks		SEE- 100 Marks	

Pre-requisite: Basic knowledge of Engineering Drawing, ability to visualise 2D and 3D views.

Course objectives:

1. Know various building components, their need and location in a building.
2. Be aware of the influence of climatic parameters on buildings, orient the building accordingly and plan sustainable water supply and energy requirement of the building.
3. Use National Building Code and local bye laws, select and use the relevant bye law according to the geographical location of the building.
4. Be aware of principles of building planning and to draw plan, elevations and section of residential and public buildings showing maximum details.
5. Be able to prepare building services drawings such as staircases, lifts and fire escapes. Prepare electrical, water supply and sanitary layout for buildings.
6. Measure an existing building using both conventional and SI units, check for deviations from local bye laws, prepare a case study and suggest remedies with relevance to cost effective building technologies.

On successful completion of the course, the student should be able to attain the following Course Outcomes:

COURSE OUTCOMES		CL	Linked PO	Teaching Hrs
CO1	Apply the concepts of building planning considering climatic parameters, building bye laws, classification of buildings and design buildings.	R/U/A	1,2,5,6,7	9
CO2	Draw site plan, plans, elevations and sectional views of residential, commercial and public buildings, showing maximum details of various building components using the available construction area effectively according to codal provisions and standard units.	R/U/A/An	1 to 9	42
CO3	Prepare building services drawings.	R/U/A/An/C	1 to 9	18
CO4	Apply his knowledge to evaluate existing projects, suggest economical modifications for sustainable development and strengthen his professional skills through self-employability and lifelong learning.	R/U/A/An/C/E	1 to 10	9



Legend: R: Remember, U: Understand, A: Apply, An: Analyse, S: Synthesise, E: Evaluate

Programme outcome Attainment Matrix

Course	Programme Outcome									
	PO1	PO2	PO3	PO4	PO5	PO6	PO7	PO8	PO9	PO10
	Basic knowledge	Discipline knowledge	Experiments and Practice	Engineering Tools	Engineer and society	Environment & Sustainability	Ethics	Individual and Team work	Communication	Life long learning
BUILDING PLANNING & DRAWING	3	3	3	3	3	3	3	3	3	1

Level 3- Highly Addressed, Level 2-Moderately Addressed, Level 1-Low Addressed.

Method is to relate the level of PO with the number of hours devoted to the COs which address the given PO.

If $\geq 40\%$ of classroom sessions addressing a particular PO, it is considered that PO is addressed at Level 3

If 25 to 40% of classroom sessions addressing a particular PO, it is considered that PO is addressed at Level 2

If 5 to 25% of classroom sessions addressing a particular PO, it is considered that PO is addressed at Level 1

If $< 5\%$ of classroom sessions addressing a particular PO, it is considered that PO is considered not-addressed.

Detailed Course Content

UNIT	COURSE CONTENT	HOURS ALLOTTED
1	<p>Introduction</p> <p>1.1 Building Planning- Factors Shape size and topography of site, Climatic conditions of the site, Functional requirements of the building, Local Bye laws- requirements of size of different components, setbacks, neighbourhood, Owner :- Status-Choices-Preferences, Economy</p> <p>1.2 Building Planning- Principles Aspects, Prospects, roominess, furniture requirements, groupings, circulation, privacy, elegance, lighting & ventilation, sanitation, flexibility, economy, practical considerations.</p> <p>1.3 Building Bye Laws Means of access, internal and external open spaces, floor area ratio, height of building, safety precautions. Building Sanction procedures- key plan (layout plan), site plan, building plan, working plan, validity of sanction, completion certificate.</p>	9



UNIT	COURSE CONTENT	HOURS ALLOTTED
2	<p>Site Plan & Planning of Buildings</p> <p>2.1 Drawing of site plan showing setbacks, Floor Area Ratio, Height of Building, and Minimum Distance from Power line, as per National Building Code (NBC).</p> <p>2.2 Given the floor area or carpet areas of rooms, plan the building and draw a Single line diagram of building.</p> <p>a) Residential building b) School Buildings c) Hostel Buildings d) Primary Health Centre</p> <p>2.3 Draw the Plan, Elevation and Sectional views for the following types of buildings.</p> <p>a) Residential buildings. b) School Buildings c) Hostel Buildings d) Primary Health Centre e) Canteen Building f) Two storied residential building g) Small work shop Building</p>	42
3	<p>Building Basic Services</p> <p>3.1 Preparation of water supply Layout for residential building.</p> <p>3.2 Preparation of Electrical Layout for residential building.</p> <p>3.3 Preparation of Sanitary Layout for residential building.</p> <p>3.4 Preparation of Shallow Well Rain Water Harvesting Method for Building.</p> <p>3.5 Preparation of Fire Fighting layout for buildings.</p>	18
	Case study	09
	Total	78

Course Delivery:

- The course will be delivered using models and Videos



SUGGESTED STUDENT ACTIVITIES

The topic should be related to the course in order to enhance his knowledge, practical skill & and lifelong learning, communication, modern tool usage. For every plan prepared calculate the Floor Area Ratio.

- Prepare a case study of nearby small public buildings verify and draw the various views and judge the prevailing bye-laws.
- Prepare a plan, elevation and section of a residential building with split floors and roofs (Split floors and roofs have different floor and roof levels).
- Develop a plan of rain water harvesting, ground water recharge and solar harvesting for your institution/any other building.
- Develop a plan of solar harvesting for your institution/any other building.
- Prepare a plan of temporary construction shed and draw various views.
- Prepare a plan of bus stand and draw various views.
- Prepare a plan of cycle stand and draw various views.



8. Study the difference between framed structure and a load bearing structure and present it.
9. Incorporate the concepts of Green building technology in your institute building.
10. Draw the plan elevation and sectional views of a pitched roof residential building.
11. Draw the plan and sectional views of a soak pit and septic tank.
12. Study of economising the cost of openings in building
13. Roof rainwater harvesting - a case study

NOTE:

1. Students should select any one of the above or other topics relevant to the subject approved by the concerned faculty, individually or in a group of 3 to 5. Students should mandatorily submit a written report and make a presentation on the topic. The task should not be repeated among students. Report will be evaluated by the faculty as per rubrics. Weightage for 5 marks Internal Assessment shall be as follows:

(Unsatisfactory **1**, Developing **2**, Satisfactory **3**, **Good4**, Exemplary**5**)

2. Reports should be made available to IA verification officer.

Example of model of rubrics / criteria for assessing student activity

Dimension	Students score				
	(Group of five students)				
	STUDENT 1	STUDENT 2	STUDENT 3	STUDENT 4	STUDENT 5
Rubric Scale	Unsatisfactory 1 , Developing 2 , Satisfactory 3 , Good 4 , Exemplary 5				
1.Literature	1				
2.Fulfill team's roles & duties	4				
3.Conclusion	3				
4.Conversions	5				
Total	13				
Average=(Total /4)	3.25=4				
Note: Concerned faculty (Course coordinator) must devise appropriate rubrics/criteria for assessing Student activity for 5 marks One activity to attain last CO (course outcome) may be given to a group of FIVE students					

Note: Dimension should be chosen related to activity and evaluated by the course faculty



Dimension	Rubric Scale				
	1 Unsatisfactory	2 Developing	3 Satisfactory	4 Good	5 Exemplary
1.Literature	Has not included relevant info	Has included few relevant info	Has included some relevant info	Has included many relevant info	Has included all relevant info needed
2.Fulfill team's roles & duties	Does not perform any duties assigned	Performs very little duties	Performs partial duties	Performs nearly all duties	Performs all duties of assigned team roles
3.Communication	Poor	Less Effective	Partially effective	Effective	Most Effective
4.Conversions	Frequent Error	More Error	Some Error	Occasional Error	No Error



TEXT BOOKS

1. Building Planning and Drawing- S.S. Bhavikatti, M.V.Chitawadagi, I.K International Publishing House Pvt.Ltd
2. Civil Engineering Drawing and design – D.N.Ghose (CBS Publishers)
3. A text Book of Draughtsman Civil(Theory and Practical) – R.S. Mallik and G.S.Meo (Asian publishers, New Delhi)
4. Building Drawing – Shah,Kale and Patki(Tata McGraw Hill Publishers)
5. Civil Engineering Drawing – Gurucharan Singh
6. Building planning and drawing - Dr. N. Kumara Swamy and A. Kameswara Rao-Charotar Publishing House Pvt.Ltd
7. Civil Engineering Drawing and House Planning - B.P.Verma, Khanna Publishers

IS-CODE

1. IS 962: 1989- Code of Practice for Architectural and Building Drawings.
2. National Building Code of India 2005

COURSE CONTENT AND EVALUATION CHART FOR SEE

Unit	Major Topics	Hours Allotted	Questions to be set for SEE						Marks weightage	weightage (%)	A*	B*	C*
			Cognitive Levels										
			R	U	Ap	Ay	C	E					
1	Introduction	9	25%	25%	25.00%	25.00%	0.00%	0.00%	16	12	8		
			4	4	4	4	0	0					
2	Site plan and planning of building	42	10%	35%	35.00%	10.00%	10.00%	0.00%	70	54		1	1
			6	25	25	7	7	0					
3	Building basic services	27	10.0%	10.0%	30.00%	20.00%	30.00%	0.00%	40	35			2
			4	4	12	8	12	0					
Total		78	15.0%	23%	30.0%	18%	13.3%	0.0%	126	100	8	1	3
			14	33	41	19	19	0					

A*-SEE QUESTIONS TO BE SET FOR (2 MARKS) in PART – A

(Answer 5 out of 8 Questions, Answers to Part A should be written on drawing sheet only)

B*- SEE QUESTIONS TO BE SET FOR (50MARKS) in PART – B (compulsory)



C*- SEE QUESTIONS TO BE SET FOR (20MARKS) in PART – C (any one)

Questions for CIE and SEE will be designed to evaluate the various educational components such as:

Sl. No	Bloom's taxonomy	% in Weightage
1	Remembering and Understanding	38
2	Applying the knowledge acquired from the course	30
3	Analysis	18
4	Synthesis (Creating new knowledge)	14
5	Evaluation	0

Course Assessment and Evaluation Chart:

	What		To whom	When/Where (Frequency in the course)	Max Marks	Evidence collected	Course outcomes
	CIE	IA					
Direct Assessment			Students	Graded Exercises	10	Drawing Sheets	1 to 4
				Student activities Case Study	15	Report + Drawings	1 to 4
	SEE	End Exam		End of the course	100	Answer scripts at BTE	1 to 4
Indirect Assessment	Student Feedback on course		Students	Middle of the course		Feedback forms	Delivery of course
	End of Course Survey			End of the course		Questionnaires	Effectiveness of Delivery of instructions & Assessment Methods

*CIE – Continuous Internal Evaluation

*SEE – Semester End Examination

Note:

1. Rubrics to be devised appropriately by the concerned faculty to assess Case study / Student activities.

Model Question Paper

III Semester Diploma In Civil Engineering

PART-A (Compulsory)

Answer any five Questions (5 x 2 =10)

1. Define working plan.
2. What is the meaning of roominess and what is the desired value.
3. State various factors that influence building planning?
4. What is Floor Area Ratio?
5. At what level are ventilators provided in bathrooms and water closets? Why?
6. Expand NBC
7. What should be the floor to floor height for Residential and public building ?
8. Mention the minimum width of landing in residential building and public building ?

PART-B

9. The line diagram shown in the figure for a proposed Residential Building with clear dimensions between inside walls (All dimensions are in mm). Draw to a scale of 1:100 the following views
 - a) Plan 20
 - b) Section on AA 20
 - c) Front Elevation 10

Foundation: Foundations shall be of C.C. 1:4:8 mix, 1000 wide and 300 thick laid at 1100 below G.L. for all main walls and verandah retaining wall. It consists of two footings of size 700 X 400 and 500 X 400 in C.M. 1:6

Basement: The basement will be in brick work in C.M. 1:5, 300 mm wide and 600 thick above G.L. A Damp Proof course in C. M. 1:3, 20 thick will be provided for all walls.

Super Structure: All main walls will be in brick work in C.M. 1:5, 200 mm thick. The inner partition walls in toilet will be 100 mm thick. The height of all the walls will be 3000 mm above floor level.

Roofing: The roofing will be R.C.C. 1:2:4 mix, 120 mm thick flat slab. Verandah slab will be of R.C.C. 1:2:4 mix, 100 thick at a height of 2600 mm from verandah floor level. A weathering course in brick jelly lime concrete plastered with mortar 1:5:9 mix, 75 mm thick will be provided.

Lintels: R.C.C. lintel 120 thick over all the openings shall be provided. Suitable sunshades for all external openings shall be provided.

Flooring: The flooring will be in C.C. 1:4:8, 120 mm thick plastered smooth with C.M. 1:3, 20 mm thick for all the portions.

Steps: Provide steps of rise 150mm and tread 250 mm

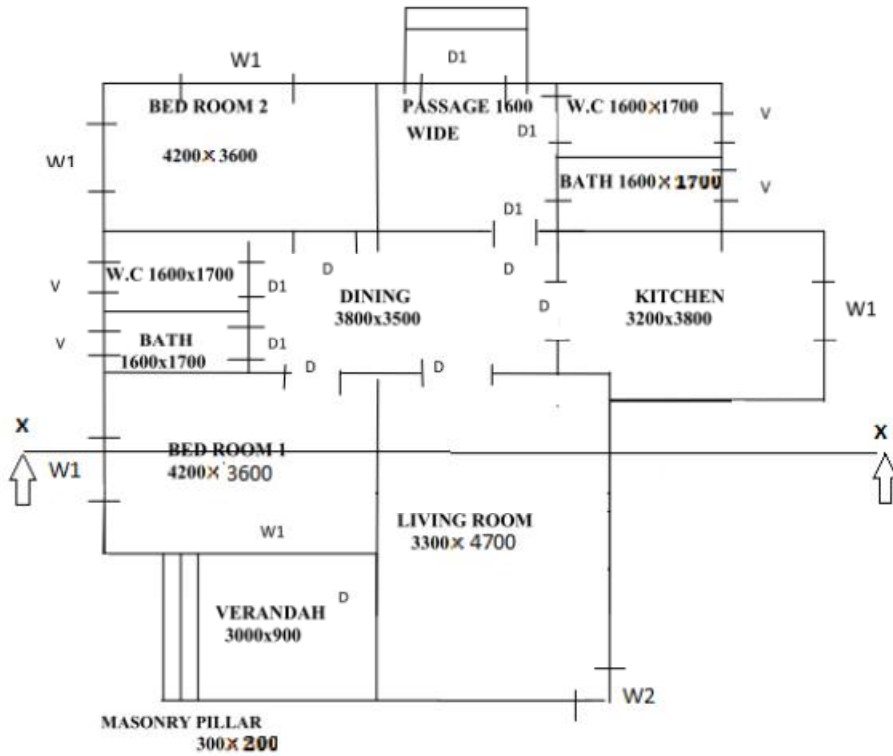

SCHEDULE OF OPENINGS		
D	FLUSH DOOR	1000 X 2100
D1	PANELLED DOOR	900 X 2100
W1	WINDOW GLAZED	1200 X 1200
V	VENTILATOR	900X300
W2	CORNER WINDOW (GLAZED)	1000x1200

PART-C

10. Draw the site plan to a scale of 1:50 and prepare a single line diagram for a residential building providing suitable room dimensions.

Site No- 50

Site Dimension – 9 m x 12 m

Orientation-

East – 30 m Road

West - Site No 115

North – Site No 51

South- Site No 49

Building Coverage 75 %

20

11. Draw the water supply layout for the given line diagram of the building

OR

Draw the plan of Shallow Well Rain Water Harvesting Method for the given line diagram of the Building.

20

MODEL QUESTION BANK

1. List the various factors to be considered for planning a residential building.
2. Why rectangular the shape of the room is preferred in buildings.
3. Mention the advantages of the site on the top of a hill or on the slope of a hill.
4. Mention the disadvantages of the site on the top of a hill.
5. What is the range of bearing capacity of the soil suitable for residential building?
6. What are the things to be avoided near the buildings?
7. What are the disadvantages of the building near to the sea shore?
8. Explain how the buildings are to be oriented in the following division of the India
a) Hot arid region b) hot humid zone c) tropical hilly region
9. What is the minimum area required for the proper ventilation.
10. Why the colour of walls, roofs, doors and windows should be lighter.
11. What is the meaning of roominess and what is the desired value.
12. What is the aspect of a kitchen in Indian residential building?
13. Where the bedroom is to be located in a building?
14. What is meant by Circulation in a building? Give guidelines for suitable circulation in a building.
15. Briefly explain the methods of ensuring natural lighting and ventilation in a building site.
16. State various factors influencing building plan.
17. What are the objectives of the building byelaws?
18. What do you mean by the means of access for a building?
19. What should be the minimum front open space for a building where the width of street fronting the plot is 7.5m?
20. What should be the minimum front open space for a building having a fronting street width less than 7.5m?
21. What should be the minimum rear open space of the building?
22. For a detached building what should be the minimum open space recommended.
23. What should be the minimum open space prescribed for a building of a height 10m.
24. What is Floor Area Ratio?
25. What is the standard specified height of the plinth from the ground level?
26. What should be the minimum height of a parapet wall?
27. What should be the maximum height of a compound wall?
28. What is the minimum grade of concrete for RCC work?
29. What should be the minimum thickness of the load bearing wall?
30. What is the minimum thickness of a slab?
31. What is the minimum size of a concrete column? Also mention the number and size of the rebar's?
32. Why the windows or ventilators are provided at higher level in bathrooms and water closet?
33. What is the difference between the key plan and site plan?
34. What do you mean by a habitable room? What are its minimum standards?
35. What do you mean by hazardous building? Give an example.
36. What is the main factor to be considered while planning?
37. Specify the minimum dimension for a living room in residential building as per the NBC standards
38. Draw the single line diagram for the given site measurements and setbacks.

39. Draw the single line diagram for the given site measurements and percentage of built up area.
40. The line diagram shown in the figure for a proposed Residential Building with clear dimensions between inside walls. Draw to a scale of 1:50 the following views
- | | |
|--------------------|----|
| a) Plan | 20 |
| b) Section on AA | 20 |
| c) Front Elevation | 10 |

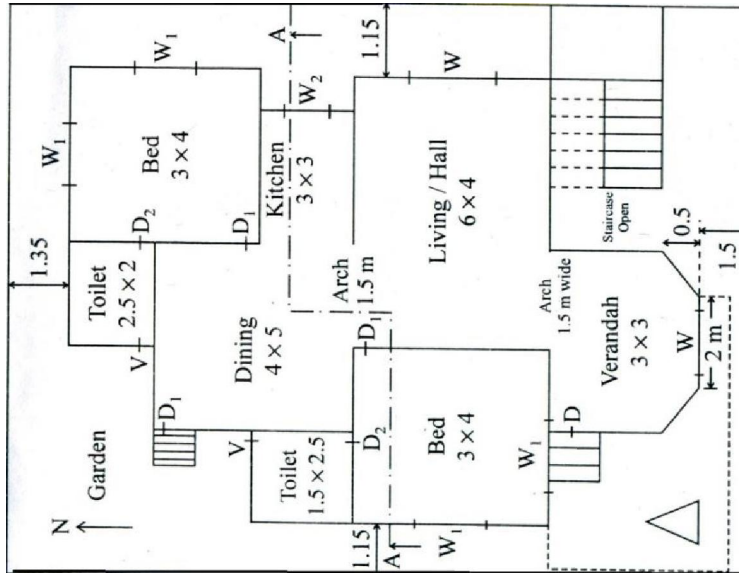

Construction details & Specifications are as follows

Foundation: 900mm wide & 1000mm deep with Concrete bed 1:4:8 200mm thick and two courses of size stone masonry in CM 1:8, 400mm depth of each course

Basement: Dressed size stone masonry in CM 1:6, 450mm wide 600mm depth includes 150mm PCC 1:3:6

Super structure:

BBM in CM 1:6 of 230mm thick for all walls

Sill 100mm thick of PCC 1:3:6

RCC Lintel 200mm thick of CC 1:2:4

RCC Chejja 600mm wide, 150mm thick at support and 50mm thick at end

RCC roof slab 150mm thick of CC 1:2:4 at 3000mm ceiling height

WPC 100mm thick average

Granite flooring 20mm thick over a CC 1:4:8 bed of 100mm thick

BBM in CM 1:6 Parapet wall of 150mm thick, 600mm height

Steps: Provide Suitable rise & tread

Schedule of Openings for Doors, Windows and Ventilators

Opening	Size
D	1100 x 2100 mm
D1	1000 x 2100 mm
D2	900 x 2100mm
W	1800 x 1200 mm
W1	1500 x 1200 mm
W2	1200x 750 mm
V	900 x 600 mm

39. Draw the water supply/sanitary layout/ electrical layout for the given plan of the building.
40. Draw the plan of Shallow Well Rain Water Harvesting Method for the given plan of the Building.

